



**EXPANSION JOINTS**

**EXPERIENCE. EXPERTISE. EXCELLENCE.**

# Metal Bellows Expansion Joints



**Knowledge Base**

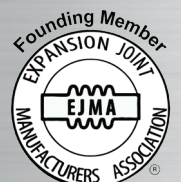



## Table of Contents

Introduction to Badger Industries	<a href="#">Pg 2</a>
About Metal Bellows Expansion Joints   Bellows Purpose	<a href="#">Pg 2</a>
Bellows Manufacturing Process	<a href="#">Pg 3</a>
Bellows Convolution Shape	<a href="#">Pg 4</a>
Movement Capabilities	<a href="#">Pg 5-6</a>
Metal Bellows   Pressure Thrust	<a href="#">Pg 7</a>
Pressure Retaining Capabilities   Bellows Squirm	<a href="#">Pg 8</a>
Bellows Stresses   Hoop Stress EJMA S2	<a href="#">Pg 9</a>
Bellows Stresses   Bulge Stress EJMA S4   Deflection EJMA S6	<a href="#">Pg 10</a>
Bellows Cycle Life	<a href="#">Pg 11</a>
Bellows Design Variables	<a href="#">Pg 12</a>
Bellows Spring Rate	<a href="#">Pg 13</a>
Bellows Components & Accessories	<a href="#">Pg 14</a>
Typical Expansion Joint Applications   Axial Movements	<a href="#">Pg 15-16</a>
Typical Expansion Joint Applications   Combined Movements	<a href="#">Pg 17-18</a>
Typical Expansion Joint Applications   Angular Movements	<a href="#">Pg 19-22</a>





# About Metal Bellows & Metal Bellows Expansion Joints

[Back to Table of Contents](#)

## Introduction to Badger Industries

Badger designed and manufactured our first metal bellows and metal bellows expansion joint in 1916. Since that time, metal bellows and metal bellows expansion joint design has improved, and the number of industrial applications grown significantly. Badger is pleased to provide insight into metal bellows purpose, design, and how metal bellows function. The data presented in this handbook is consistent with the Standards of the Expansion Joint Manufacturers Association (EJMA), of which Badger is a founding member.



## Metal Bellows Purpose

Metal Bellows are used to absorb thermal movements of pressure vessels, piping and ducting systems while retaining system design pressure at system design temperature. Regardless of the manufacturer and manufacturing method, the metal bellows terminology is consistent.

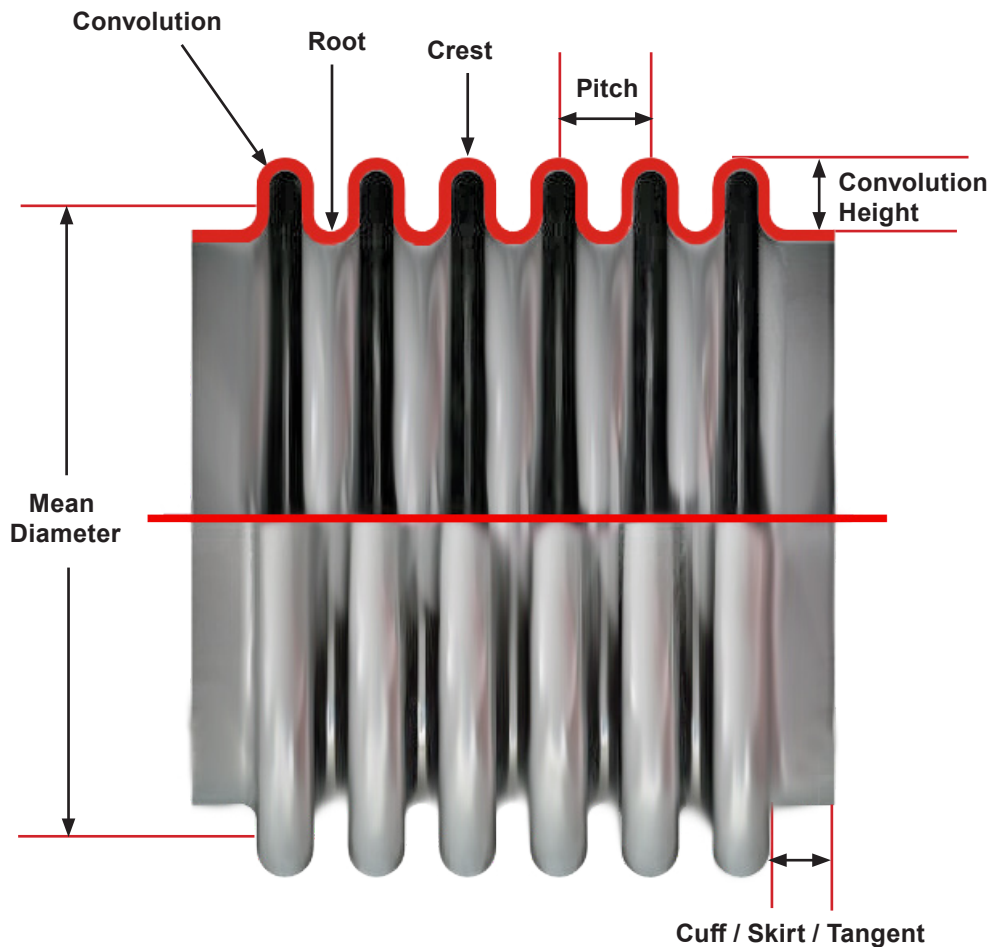



[Back to Table of Contents](#)

Metal Bellows are designed in accordance with EJMA Standards and, as applicable, ASME Section VIII Division 1 or 2 design codes.

## Bellows Design & Manufacturing Process

1. Metal bellows manufacturing starts with the customer's selection of ASTM or ASME material based on system design. Bellows ply thickness, number of convolutions, and convolution height and pitch are determined by Badger. Typical ply thickness for metal bellows ranges from .010" to .078". Minimum thickness is .005" and maximum thickness is .125", depending on the forming method used.
2. The bellows material is sheared to close tolerance dimensions depending on diameter and final convoluted length.
3. The material is then rolled into a tube, welded, and planished.
4. The tubes are then processed on a bellows forming machine to Badger design requirements.

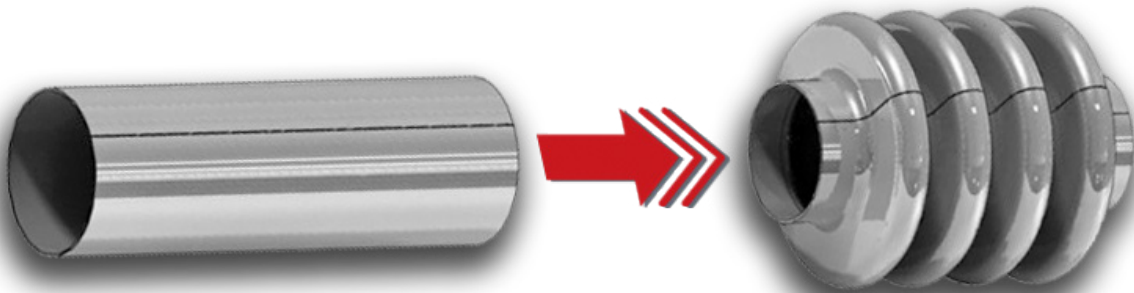

*After material selection, the bellows material is sheared and rolled into a tube, welded, and planished (as shown on the left). The tube is then processed on a bellows forming machine to add the convolutions as shown on the right.*

5. Badger manufactures metal bellows using the following forming methods:
  - a. Hydroforming (Hydraulic Forming)
  - b. Pneumatic Tube Forming
  - c. Roll Forming
  - d. Expanding Mandrel Forming



# Metal Bellows Convolution Shapes

[Back to Table of Contents](#)

Typical convolution shapes are: **U Shape** and **Toroidal**

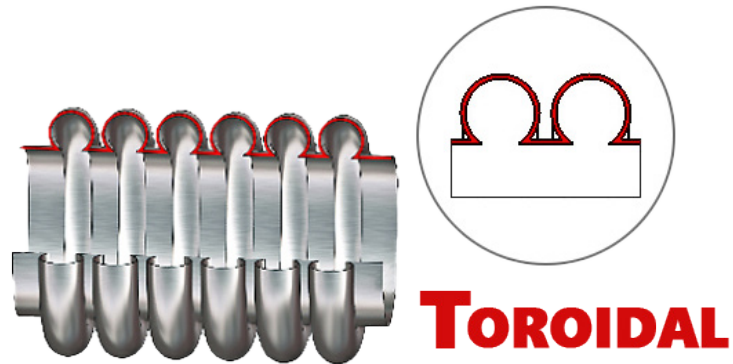
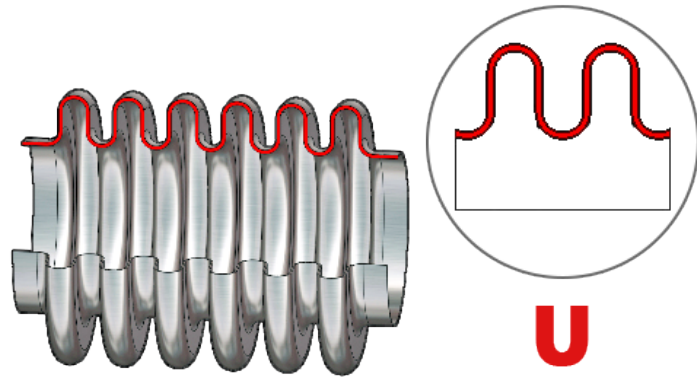



# Metal Bellows Movement Capabilities

[Back to Table of Contents](#)

By design, metal bellows reduce the stress from thermal movement in piping systems and pressure vessels by compressing or expanding at elevated or reduced temperatures.

There are (3) main types of movements that can be absorbed by metal bellows:

## Axial Movement

Axial movement is the change in free length of the bellows along its longitudinal axis. *Compression* is expressed as negative (-) and *Extension* as positive (+). Axial spring rates are expressed in pounds force per inch (lbf/in.) of movement.

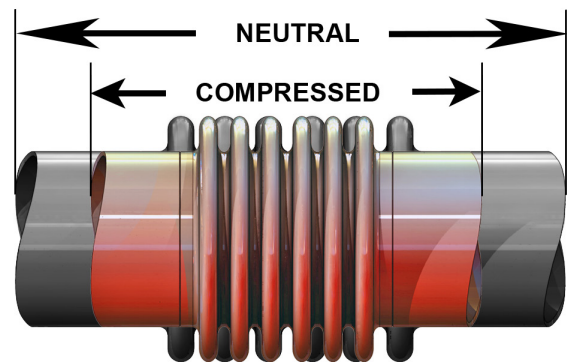

## Angular Movement

Angular movement is the bending of the metal bellows longitudinal axis into an arc. While the convolutions at the inner most point are in *compression* (-), those furthest away are in *extension* (+). Angular spring rates are expressed in inch pounds force - inch per degree (lbf-in/deg.) of movement.

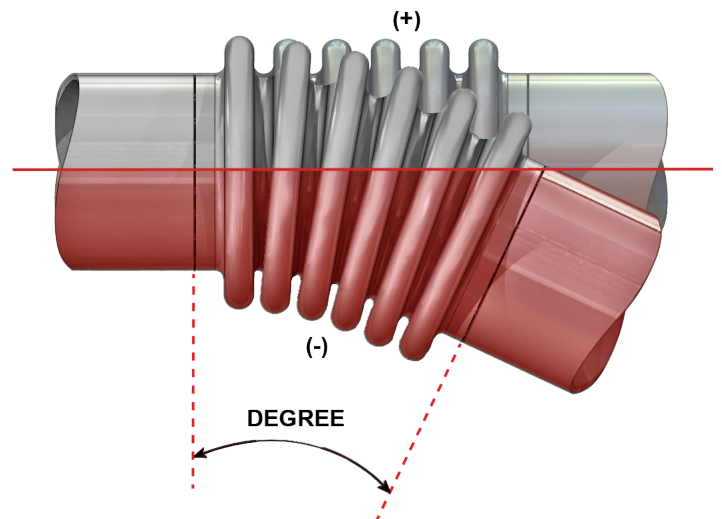



# Metal Bellows Movement Capabilities

[Back to Table of Contents](#)

## Lateral Movement

Lateral movement is the relative displacement of one end of the bellows to the other end perpendicular to its longitudinal axis. Lateral movement can be imposed on a single bellows or across two bellows for greater offset movements and much lower offset forces. The units for lateral spring rates are in pounds force per inch (lbf/in.) of movement.

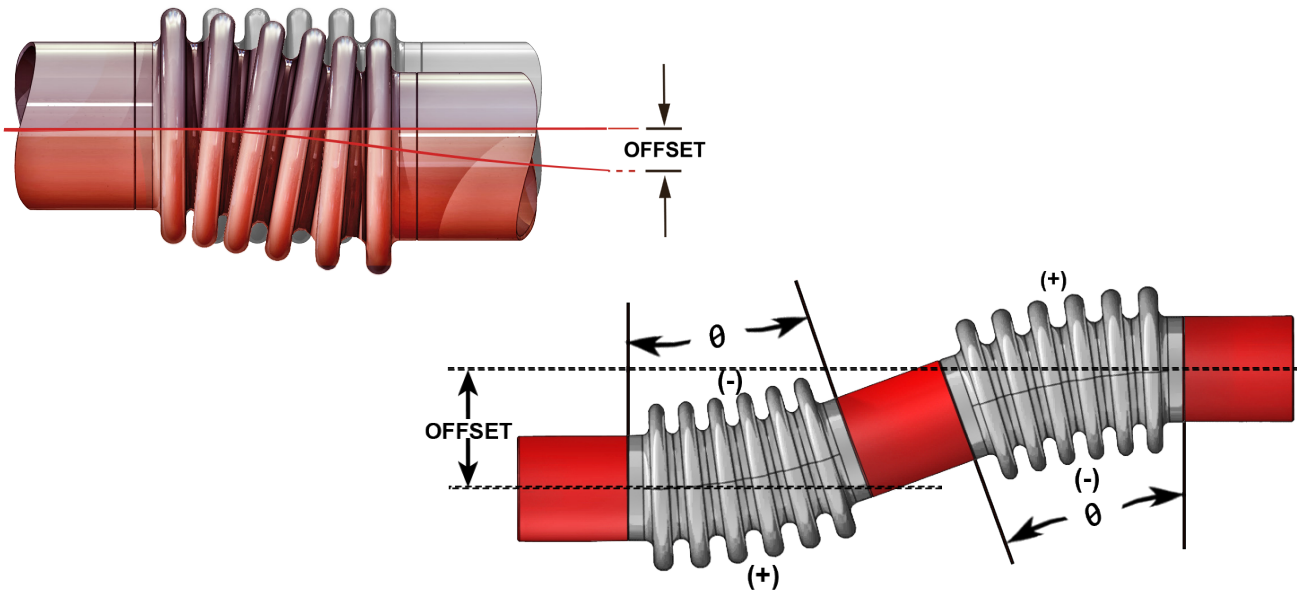

## Torsional Movement

Metal bellows cannot absorb torsional motion or twisting; however, they can be designed to resist torsional force.

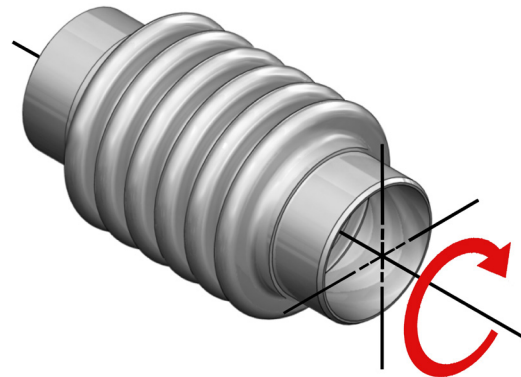

## Resonant Vibration

Resonant vibration can cause immediate failure of a metal bellows. Metal bellows must be designed to not react to vibration loads in piping and ducting systems imposed by rotating equipment.

## Bellows Pressure Thrust

Bellows pressure thrust force is the result of the system operating or test pressure being applied to the effective area (based on the mean diameter) of the bellows and is larger than the pressure thrust force of the connected pipe.

### Mean Diameter

$$\text{Bellows I.D.} + \left( \frac{\text{O.D.} - \text{I.D.}}{2} \right)$$

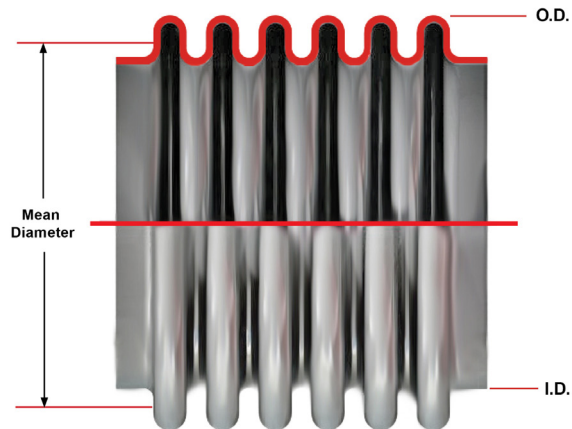

Pressure thrust forces are typically higher than all other system forces and are usually restrained by system anchors. If anchoring is insufficient or absent, bellows pressure thrust forces can also be restrained by externally-attached hardware such as Tie Rods, Hinges, or Gimbals.

### Pressure Thrust Force

$$F = P \cdot a$$

**F** is Force (lbf)

**P** is Pressure (psig)

**a** is the Effective Area of the Bellows (in.<sup>2</sup>)

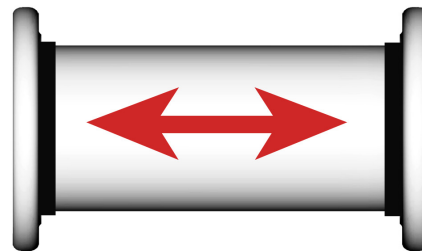

*Shown here, pressure thrust is restrained by the strength of the pipe between the blind flange attachments*

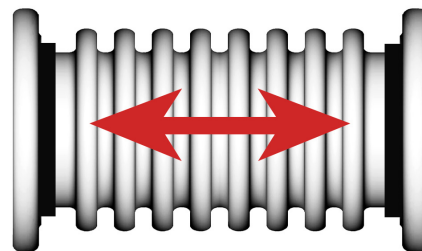

*When blind flanges are attached to the ends of an unrestrained metal bellows, the bellows response to pressure thrust results in the bellows convolutions stretching out until it returns to its original tube form.*





# Metal Bellows Pressure Retaining Capabilities

[Back to Table of Contents](#)

## Pressure Retaining

Pressure Retaining capability of a bellows is based on the material type and thickness, bellows convolution geometry, and number of convolutions. Bellows design is complex. See the Bellows Design Variable chart on page 12 to better understand the variables of metal bellows design.

## Bellows Squirm

Bellows Squirm results from over pressurization, and/or improper guiding of an installed metal bellows expansion joint. Squirm leads to permanent deformation and/or immediate failure of the bellows.

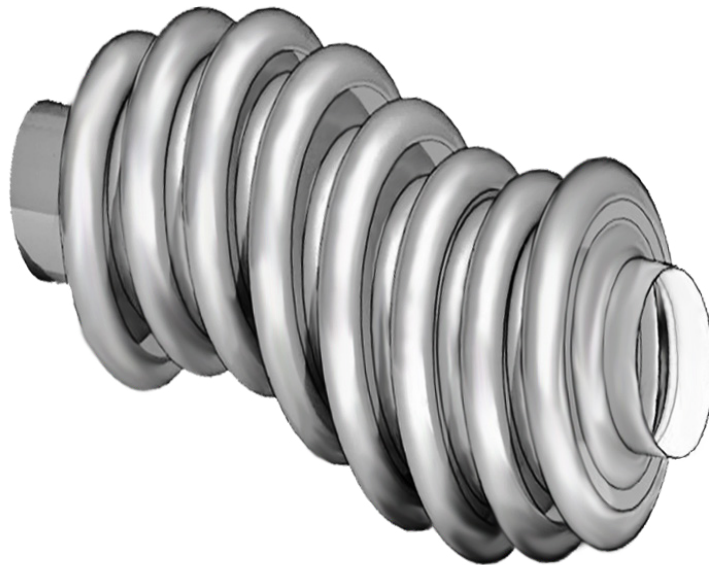

## Hoop Stress

Hoop stress, EJMA "S2", runs circumferentially around the bellows resulting from pressure differential between the inside and outside diameter of the bellows.

EJMA S2

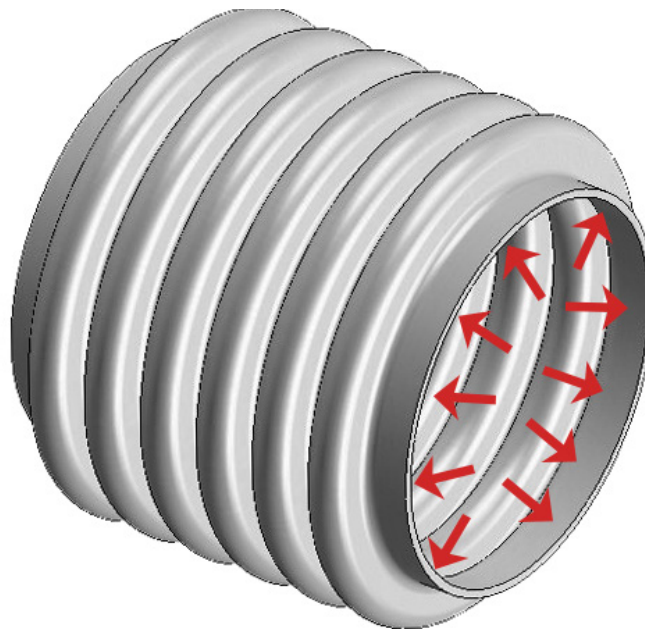

## Bulge Stress

Bulge stress, EJMA "S4", runs longitudinal to the bellows centerline acting on the sidewall of the bellows convolutions.

EJMA S4

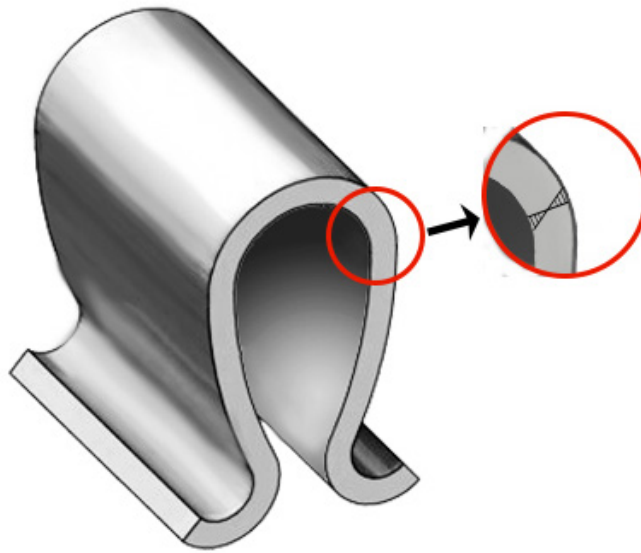

## Deflection Bending Stress

Deflection Bending Stress, EJMA "S6", is stress resulting from deformation of the side walls of the convolutions caused by movement of the bellows as it compresses, extends or angulates. The stress is highest in the crest and root of the convolutions.

EJMA S6

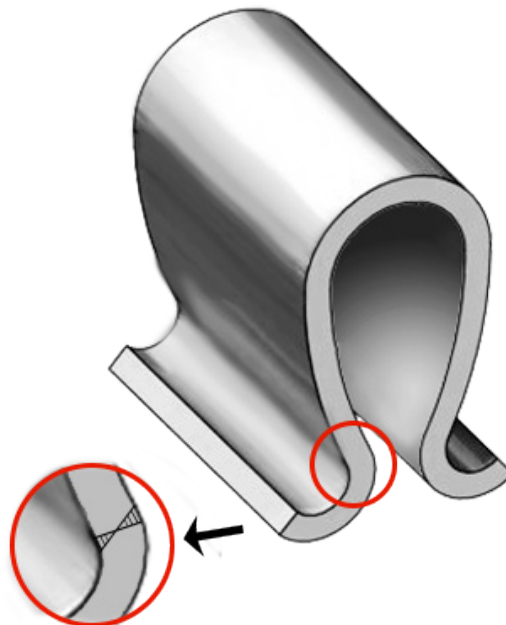

Metal bellows movements are normally designed to operate in the plastic range of materials and therefore will take a permanent “set” at the bellows rated movements. When a bellows compresses, extends, or angulates, the movement is absorbed by deformation of the side walls of the bellows convolutions. The stress caused by the side wall deformation is defined as the “deflection bending stress, EJMA S6”. This stress is highest at the “root” and “crest” of the convolution.

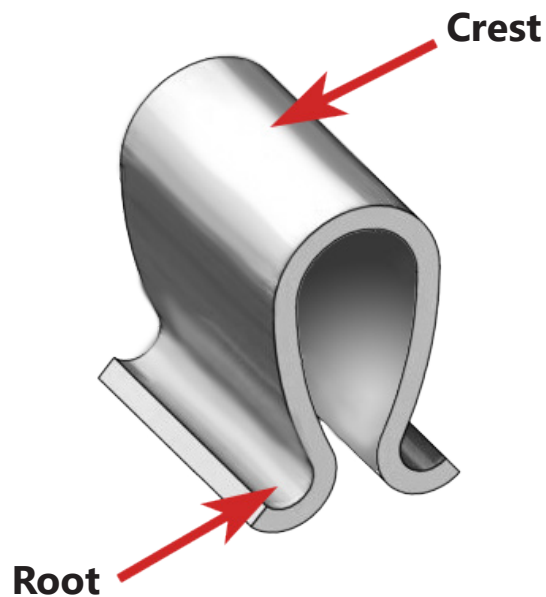

Metal bellows are designed to operate with a deflection bending stress that greatly exceeds the yield strength of the bellows material and therefore operate in the plastic range of the material. Because of this, the bellows will eventually fail after a finite number of movement cycles. Bellows designed to the EJMA standards have proven reliability of cycle life, and realistic cycle life should be stated in the specifications. Refer to the chart on the next page, “higher” cycle life results in “weaker” (pressure) bellows. Optimum bellows design is based on accurate-real-world cycle life, pressure, temperature and bellows movement data.





# Metal Bellows Design Variables

[Back to Table of Contents](#)

The EJMA standard covers the subject of bellows cycle life in depth. Badger recommends that system designers refer to the EJMA Standards when specifying cycle life.

The chart below will help understanding the relationship of pressure and cycle life in bellows design.

Bellows Design Variables	Hoop Stress EJMA S2	Bulge Stress EJMA S4	Deflection Stress EJMA S6	Squirm Pressure	External Buckling Pressure	Cycle Life	Rated Axial	Rated Lateral	Rated Angular	Axial Spring Rate	Lateral Spring Rate	Angular Spring Rate	Pressure Thrust
Thicker Material	-	-(2)	+	+(3)	+	-	-	-	-	+(3)	+(3)	+(3)	S
Thinner Material	+	+(2)	-	-(3)	-	+	+	+	+	-(3)	-(3)	-(3)	S
Higher Convolution	-	+(2)	-(2)	-(3)	+	+	+	+	+	-(3)	-(3)	-(3)	+
Lower Convolution	+	-(2)	+(2)	+(3)	-	-	-	-	-	+(3)	+(3)	+(3)	S
Smaller Pitch	-	+	-	-	+	+	+	+	+	-	-	-	S
Larger Pitch	+	-	+	+	-	-	-	-	-	+	+	+	S
More Plies	-	-	S	+	+	S	S	S	S	+	+	+	S
Fewer Plies	+	+	S	-	-	S	S	S	S	-	-	-	S
Larger Diameter	+	S	S	+	-	S	S	-	-	+	+	+	+
Smaller Diameter	-	S	S	-	+	S	S	+	+	-	-	-	S
More Convolution	S	S	-	-	S	+	+	+	+	-	-	-	S
Less Convolution	S	S	+	+	S	-	-	-	-	+	+	+	S

**Legend**    + = Increase    - = Decrease    S = Same    (2) = Value Squared    (3) = Value Cubed

**Note:** The red values in the chart indicate that when cycle life is higher, squirm pressure is lower.



# Metal Bellows Spring Rate

[Back to Table of Contents](#)

Metal bellows spring rate is the force required to compress, extend or angulate the bellows. Spring rate is expressed as pounds force per inch (lbf/in.) for compression, extension and lateral movement, and as pounds force-inch per degree (lbf-in./deg.) for angular movement.

The spring force of a metal bellows is calculated as  $F = K * X$ , where:

**F** is the force imposed on equipment on either end of the bellows

**K** is the bellows spring rate

**X** is the specified design movement

The spring force of a bellows is additive to the pressure thrust force unless the pressure thrust force is retained in the metal bellows expansion joint.

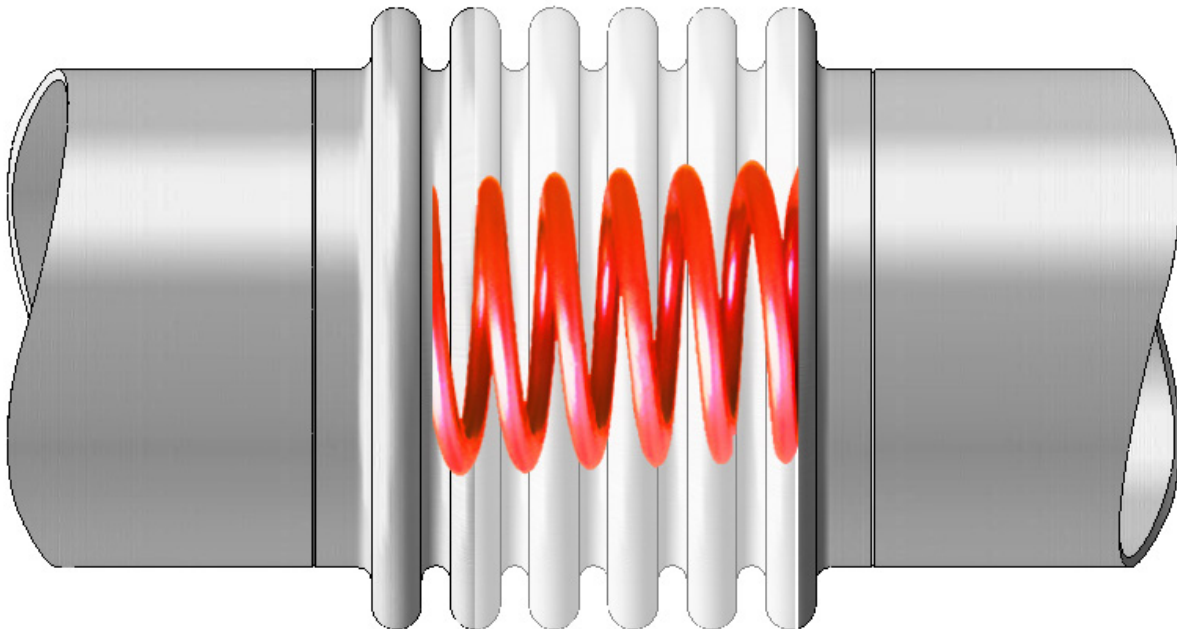



# Metal Bellows Expansion Joint Components & Accessories

[Back to Table of Contents](#)

Metal bellows and metal bellows expansion joints have the same basic components regardless of the manufacturer and manufacturing method. Adding accessories and end connections to the bellows increases its capabilities making the expansion joint functional for a wide range of applications.

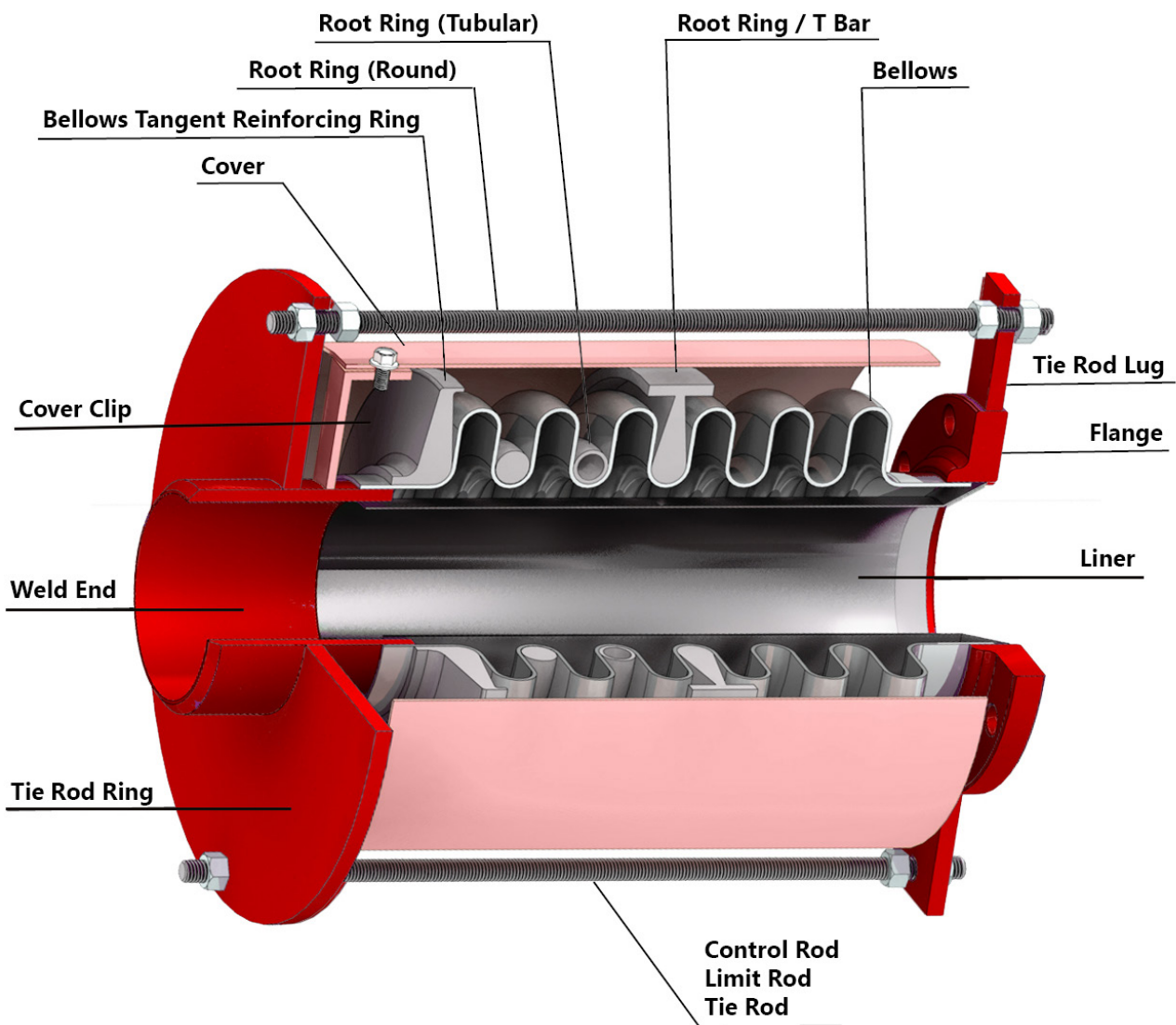



# Typical Expansion Joint Applications

[Back to Table of Contents](#)

## Single Bellows Expansion Joint

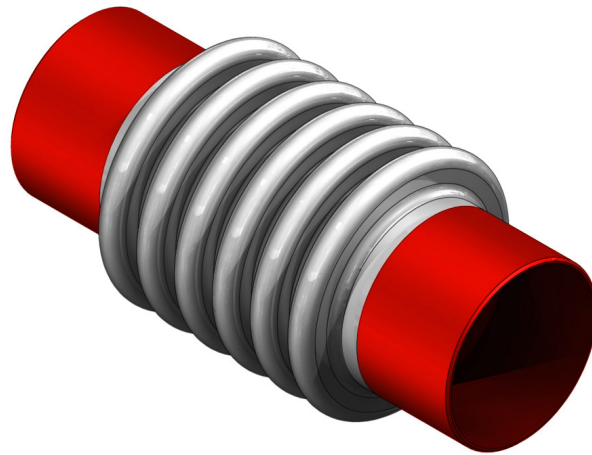

## Pressure Balanced Expansion Joint

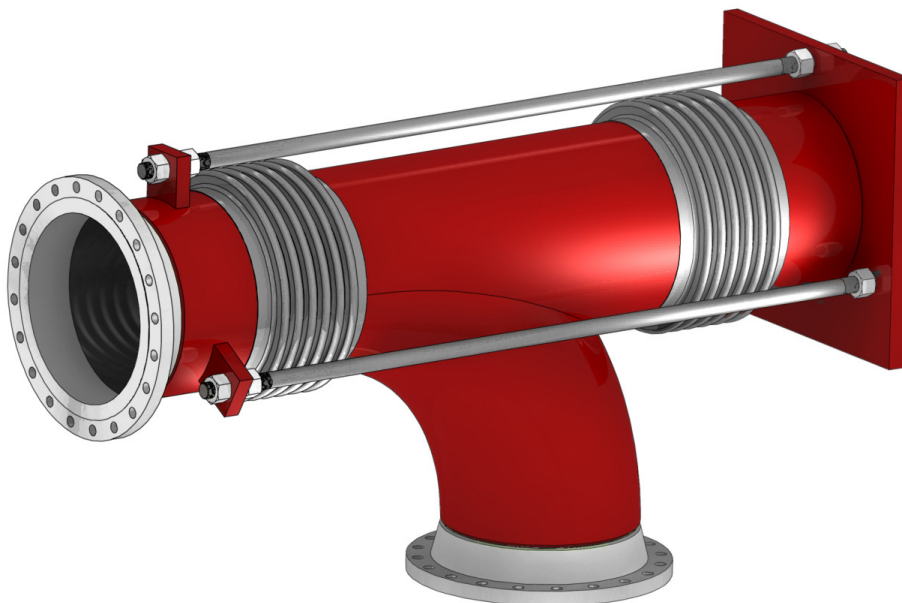





[Back to Table of Contents](#)

## Single Expansion Joint

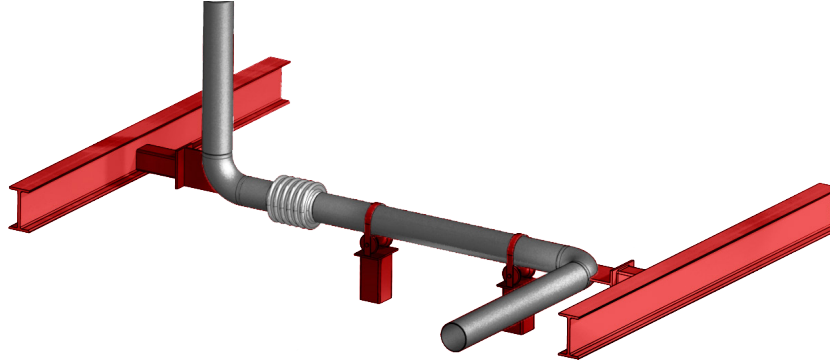

## Double Expansion Joint with Intermediate Anchors Installed

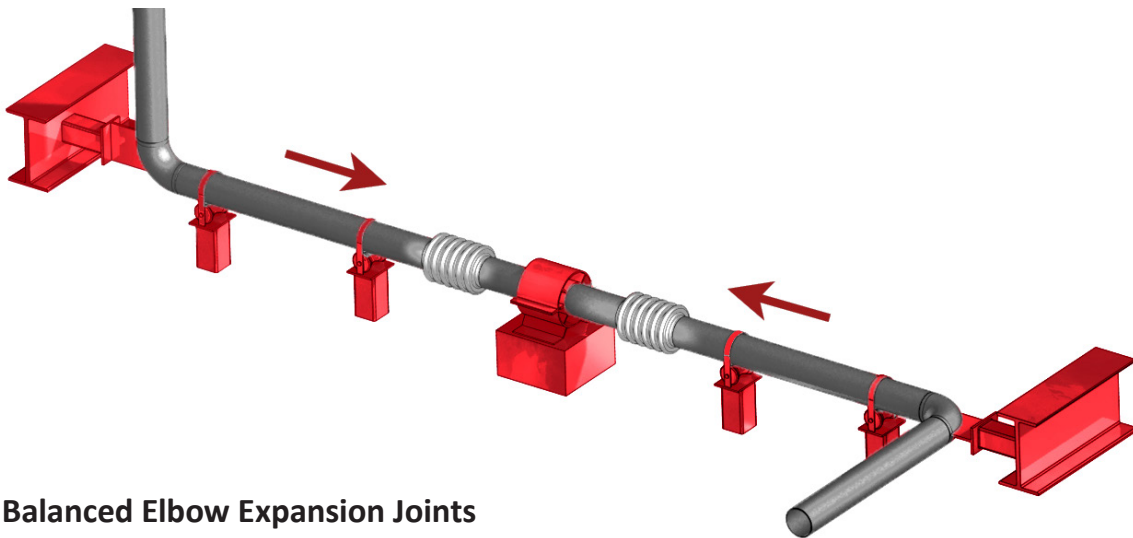

## Pressure Balanced Elbow Expansion Joints

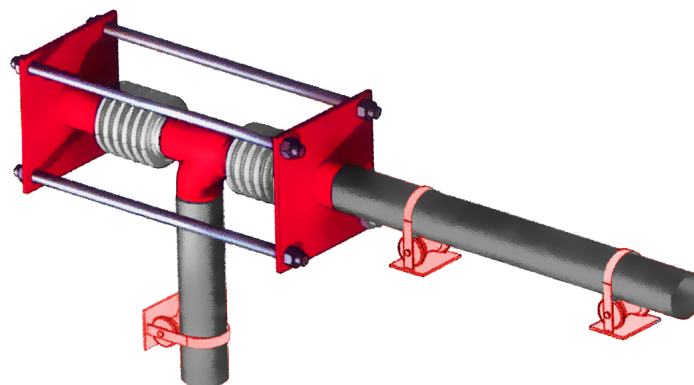



# Typical Expansion Joint Applications

[Back to Table of Contents](#)

## Tied Single Expansion Joint

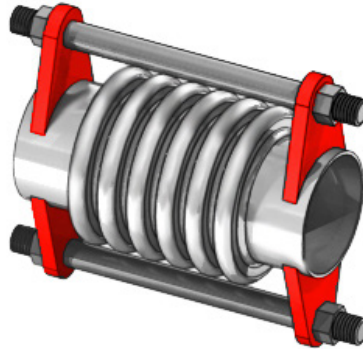

## Tied Universal Expansion Joint

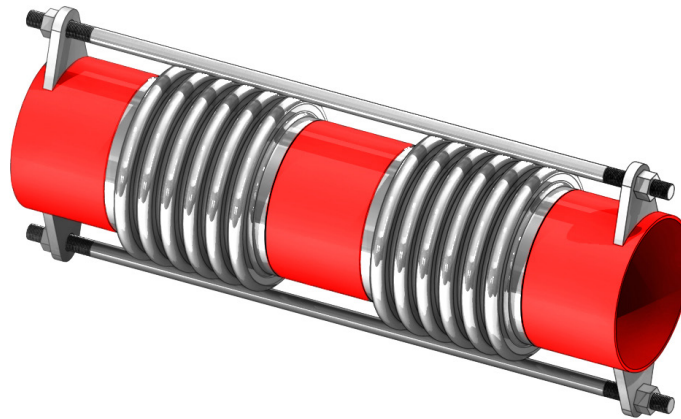

## Single Expansion Joint Combined Axial and Lateral Movement

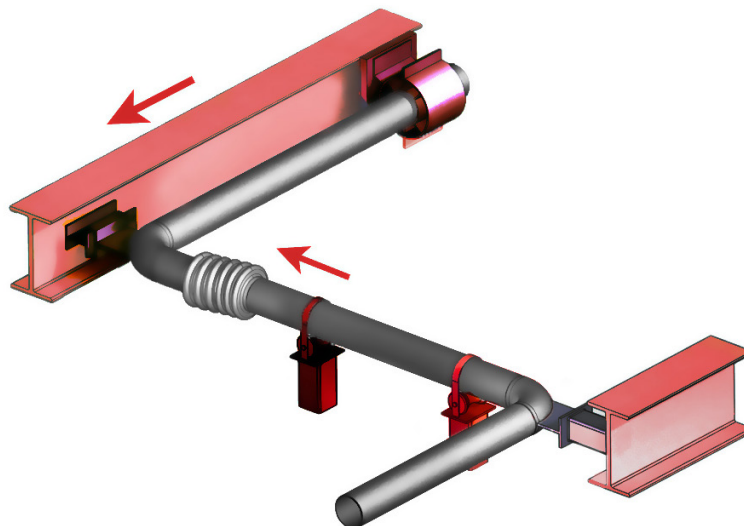

## Tied Single Expansion Joint for Lateral Movement

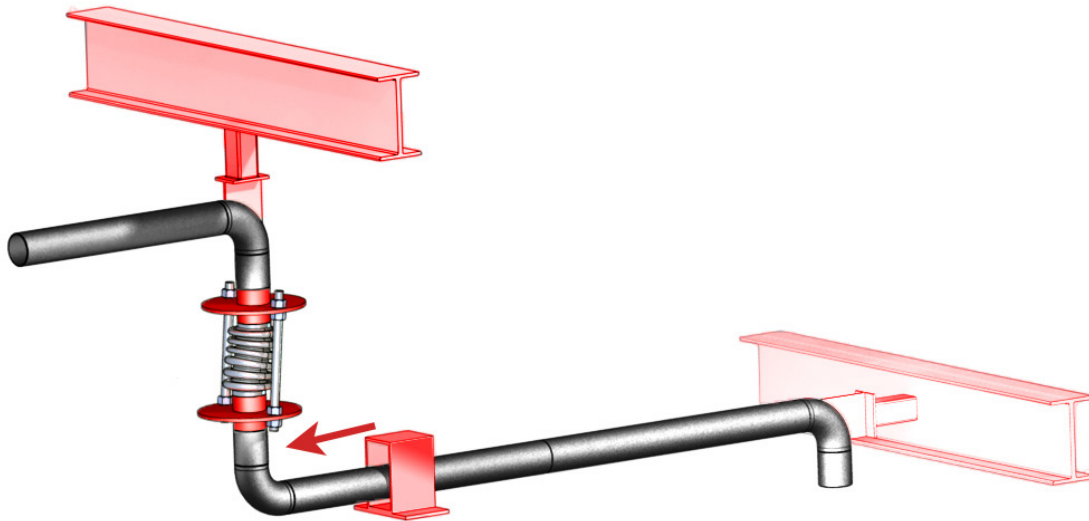

## Tied Universal Expansion Joint for Lateral Movement

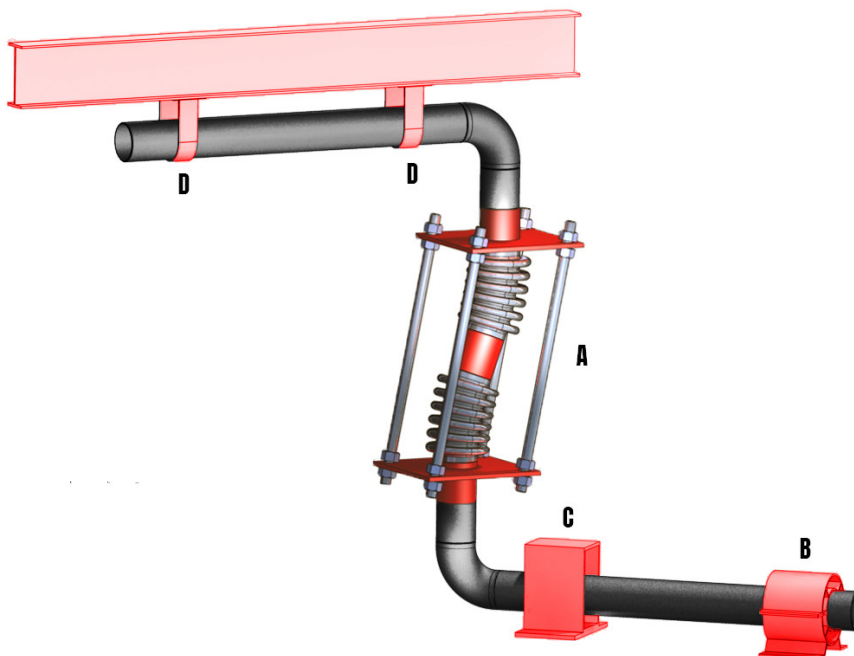



# Typical Expansion Joint Applications

[Back to Table of Contents](#)

## Hinged Expansion Joint

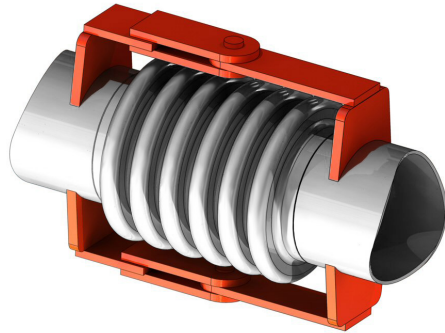

## Gimbal Expansion Joint

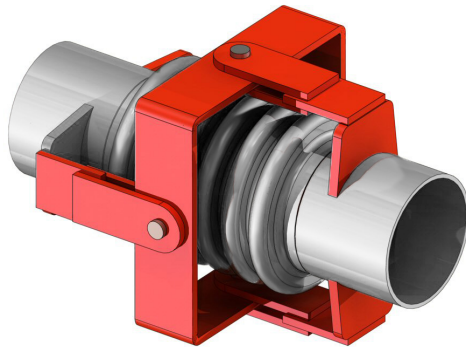

## Universal Hinged Expansion Joints

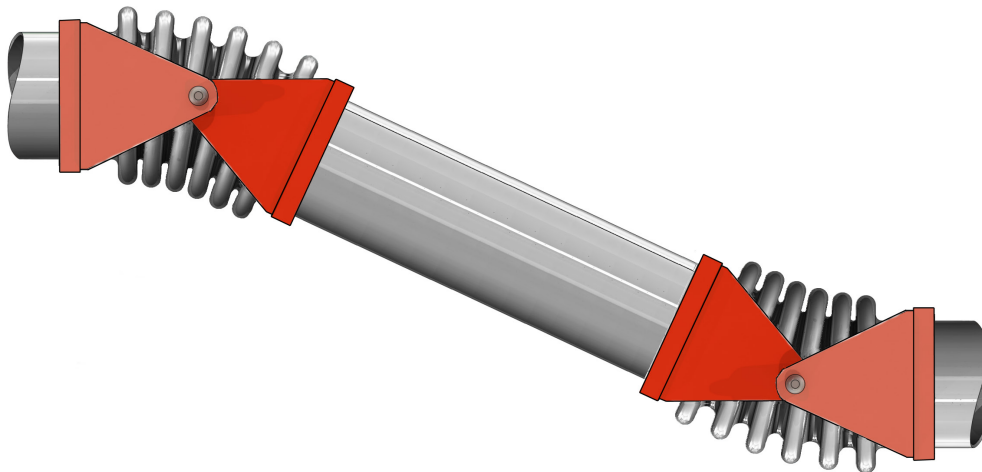





# Angular Movements

[Back to Table of Contents](#)

**Two Hinged Application**

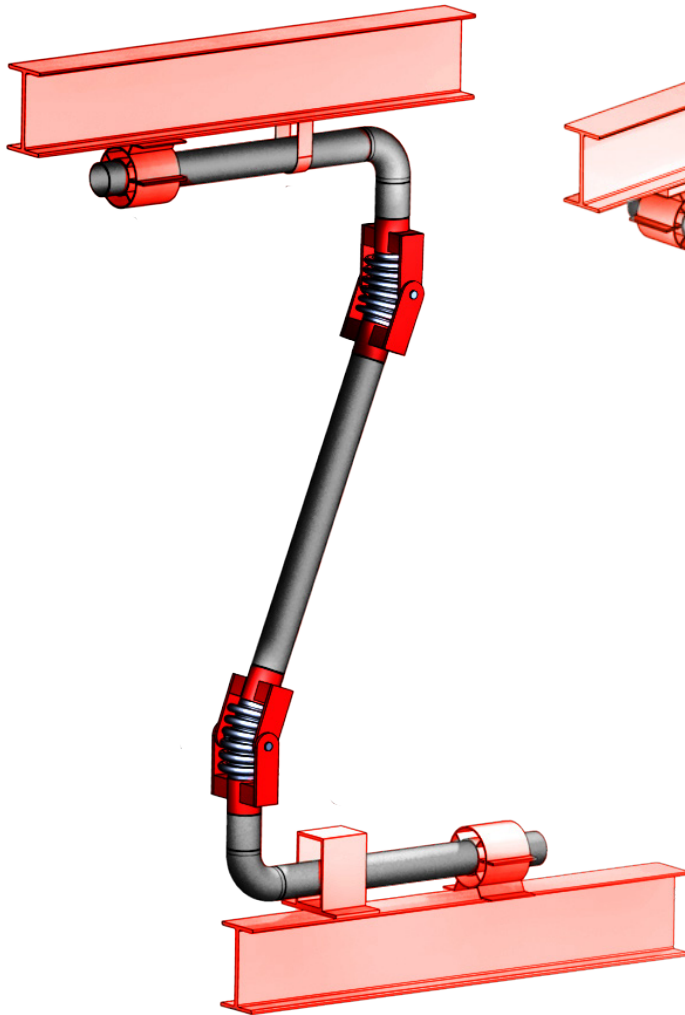

**Three Hinged Application**

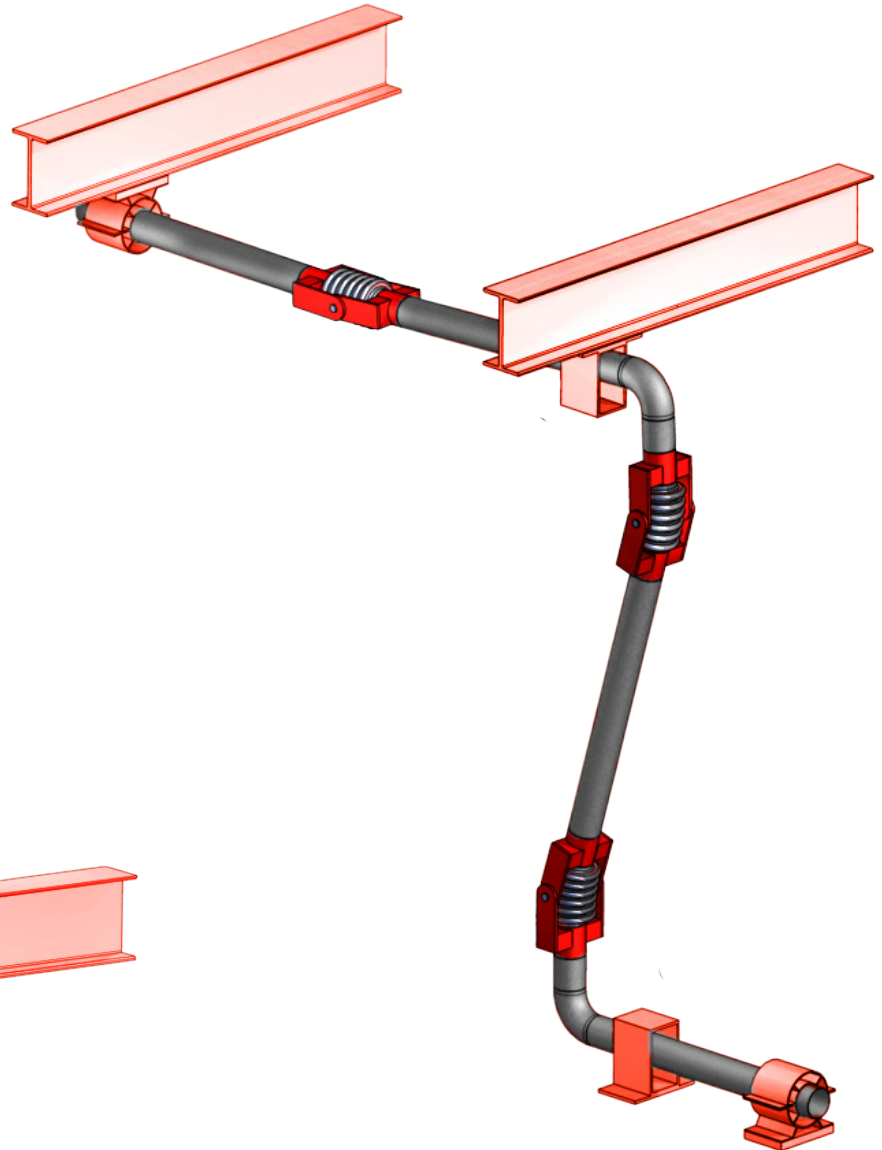



# Typical Expansion Joint Applications

[Back to Table of Contents](#)

## Two Gimbal Application

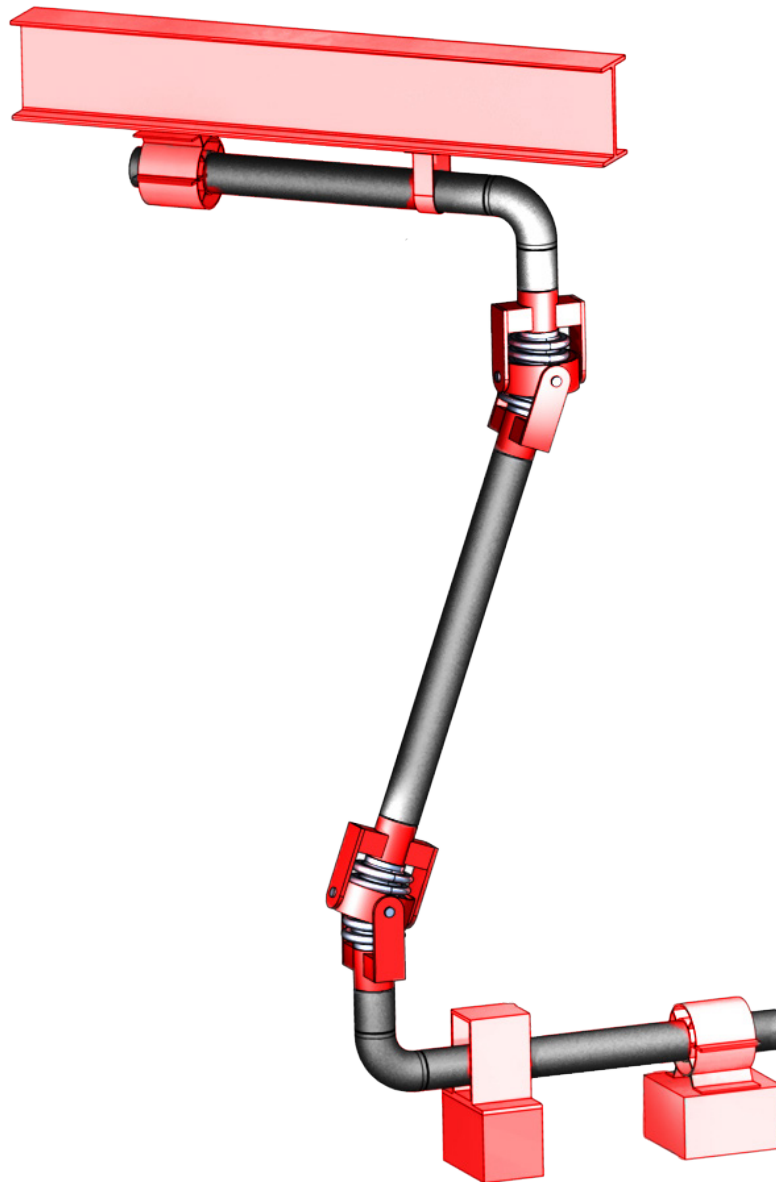



[Back to Table of Contents](#)

## Two Gimbal and One Hinge Application

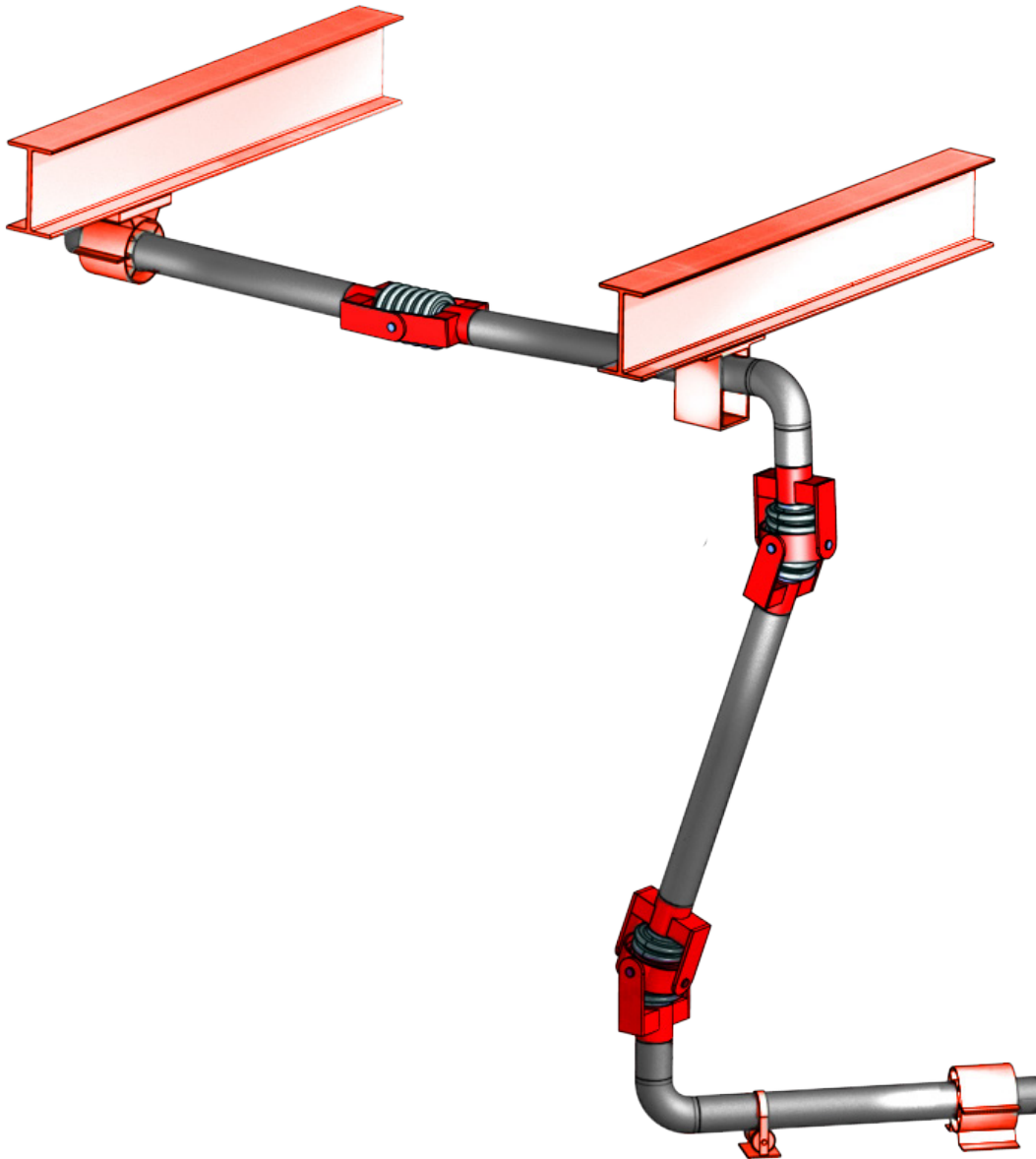

# A Century of Excellence



*Badger Industries' 127,000 ft<sup>2</sup> manufacturing space on 16.5 Acres in Zelienople, PA*



Badger Industries has been in continuous operation since 1841. Badger began as “Coppersmiths” and metal expansion joints became a large part of the business starting in 1916. Throughout the 20th Century and into the 21st, Badger engineered expansion joint products have been approved by leading engineering and end user companies. The results are Badger’s fabric and metal expansion joints installed worldwide in power generation, refining, chemical, pipelines, steel, smelting, pulp & paper, and other industries.

Badger...moving forward to another Century of Excellence.

Badger manufactures and provides services such as inspection, installation, and repair of fabric and metal expansion joints for most industries including chemical, power generation, oil refining, and turbine-driven pipeline stations. Specific expansion joint applications include: Boiler Penetration Seals, Turbine Crossover, Steam Extraction, HRSG, Gas Turbine, FCCU, Heat Exchangers, SCR, and Styrene.



**EXPANSION JOINTS**

**EXPERIENCE. EXPERTISE. EXCELLENCE.**



**BADGER INDUSTRIES**  
A Division of Markovitz Enterprises, Inc.  
100 Badger Drive • Zelienople, PA 16063 • Tel: (724) 452 4500  
[sales@badgerind.com](mailto:sales@badgerind.com) • [www.badgerind.com](http://www.badgerind.com)